



Hornady

LOCK-N-LOAD[®] HEADSPACE COMPARATOR KIT

Extend brass life, improve accuracy and enhance safety.

The **Hornady Headspace Comparator** is the best method we've found to extend brass life, improve accuracy, and enhance safety. The comparator measures variations in your brass before and after firing, or resizing. It allows comparison between fire-formed brass and your resized brass. Any of five interchangeable bushings attach to your caliper using the same B-2000 body as found on our Bullet Comparator.

After attaching to your caliper with the brass thumbscrew, simply select the proper bushing (see chart) to measure your cases from the case-head to the comparative point on the case shoulder. Typically, when full-length resizing, the die should be adjusted to set the shoulder back .001" to .002". This will provide a proper (minimal) clearance with the firearm's chamber. A proper headspace will minimize case stretching, reduce work hardening, extend case life, improve accuracy, and increase safety.

For the shooter with an autoloader, check your fired cases by rotating the brass in the Headspace Comparator to identify cases with bent rims – a certain cause of "flyers." You can also identify excessive headspace conditions, which is a potentially dangerous situation. Proper headspace also provides proper firing pin contact with the primer to improve the reliability of your loads.

The five bushings that come with the Hornady Headspace Comparator Kit provide the ability to check most bottleneck cases, from .17 Remington through the belted magnums. Ackley Improved chambers use the same bushing size as the parent case. See chart provided or consult product instructions for cartridge/bushing size details.

Hornady Headspace Bushing Size Chart:

- A - .330" .17 Rem, 204 Ruger, 221 Rem FB, 222 Rem, 222 Rem Mag, 223 Rem, 220 Swift
- B - .350" 22PPC, 22/250 Rem, 6PPC, 6BR Rem, 250 Savage, 7BR Rem
- C - .375" 6mm Rem, 257 Rob, 25/06 Rem, 270 Win, 7x57mm Mauser, 280 Rem, 30/30 Win, 30/06 Sprg, 300 H&H Mag, 7.62x39 Brit, 6.5x55 Mauser, 7mm WSM, 303 Brit, 30-40 Krag
- D - .400" 223 WSSM, 243 Win, 243 WSSM, 260 Rem, 270 WSM, 7mm/08 Rem, 300 Savage, 308 Win, 35 Rem
- E - .420" 6.5x284, 284 Win, 7mm Rem Mag, 7mm Ultra Mag, 300 WSM, 300 Wby Mag, 325 WSM, 338 Win Mag, 350 Rem Mag, 375 H&H Mag, 264 Win Mag, 7mm SAUM, 7mm STW, 300 RSAUM, 300 Win Mag, 300 Ultra Mag, 8mm Rem Mag, 338 Ultra Mag, 35 Whelen

Note: Many Weatherby cases may be checked by measuring cases on the inside radius and on the outside radius. Use the appropriate bushing size(s) to gauge near the center of the radius.

WARNING: This product contains lead, a chemical known to cause cancer, birth defects and other reproductive harm.



WARNING: Cancer and Reproductive Harm – www.P65Warnings.ca.gov



Hornady

Hornady Manufacturing Company
Box 1848, Grand Island, NE 68802-1848
www.hornady.com

69049

Item No. HK66



Install the brass Thumb Screw into the threaded hole in the B-2000 Body, which will allow the Body to center on your caliper blade. From the chart below, select and insert the proper Bushing into the Body, then position the assembly on your caliper blade. Close the caliper blades snugly to align the assembly with your caliper, then tighten the Set Screw and Thumb Screw.

Determining the proper Bushing diameter: If you add the neck diameter and the shoulder diameter and divide that number by two, you will know the proper bushing diameter to use.

- A - .330" .17 Rem, 204 Ruger, 221 Rem FB, 222 Rem, 222 Rem Mag, 223 Rem, 220 Swift
- B - .350" 22PPC, 22/250 Rem, 6PPC, 6BR Rem, 250 Savage, 7BR Rem
- C - .375" 6mm Rem, 257 Rob, 25/06 Rem, 270 Win, 7x57mm Mauser, 280 Rem, 30/30 Win, 30/06 Sprg, 300 H&H Mag, 7.62x39 Brit, 6.5x55 Mauser, 7mm WSM, 303 Brit, 30-40 Krag
- D - .400" 223 WSSM, 243 Win, 243 WSSM, 260 Rem, 270 WSM, 7mm/08 Rem, 300 Savage, 308 Win, 35 Rem
- E - .420" 6.5x284, 284 Win, 7mm Rem Mag, 7mm Ultra Mag, 300 WSM, 300 Wby Mag, 325 WSM, 338 Win Mag, 350 Rem Mag, 375 H&H Mag, 264 Win Mag, 7mm SAUM, 7mm STW, 300 RSAUM, 300 Win Mag, 300 Ultra Mag, 8mm Rem Mag, 338 Ultra Mag, 35 Whelen

SOLD SEPARATELY

F - .188" Bushing "blank" with .188" diameter hole. Drill and ream for sizes not listed.

G - .240" 17 Hornet

Consult reloading manual and/or cartridge drawings for additional case models.

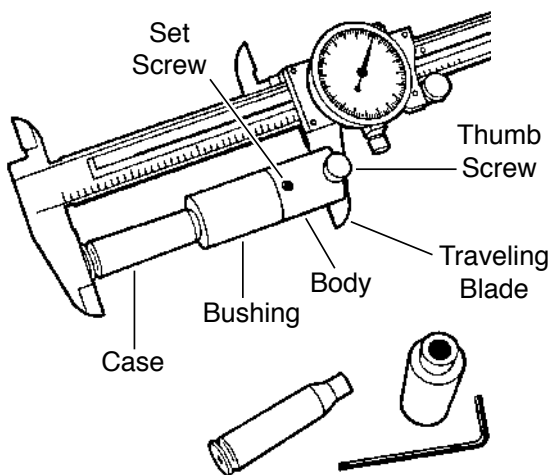

Now, open the caliper and center the case shoulder into the Bushing. Bring the caliper blade to rest on the case head and rotate the case as you remove slack, then take a reading. Be consistent! Most handloaders prefer to carefully "zero" the caliper's indicator on the longest (fire-formed) case. This allows them to gauge the headspace variations from this fire-formed (maximum) case dimension.

Many experienced handloaders prefer to set the case's shoulder back .001" to .002" from the fire-formed case dimension to achieve a close fit with the chamber. This reduces case stretching to a minimum, reduces work-hardening, extends case life, and improves accuracy.

Remember: Different lots of fire-formed brass may measure differently due to alloy and temper variations in the brass. Also, work-hardening, which results re-sizing and firing, will have an effect. The type and amount of lubrication applied to the cases can have an effect on the re-sized dimensions. A variation in your lube technique can and will be detected by the gauge. Always adjust re-sizing dies in small increments to achieve the desired results.

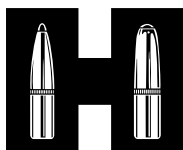

Hornady®